

8 7 6 5 4 3 2 1

REVISIONS				
ZONE	REV.	DESCRIPTION	DATE	APPROVED
	A	Check-in	7/21/2011	DRP

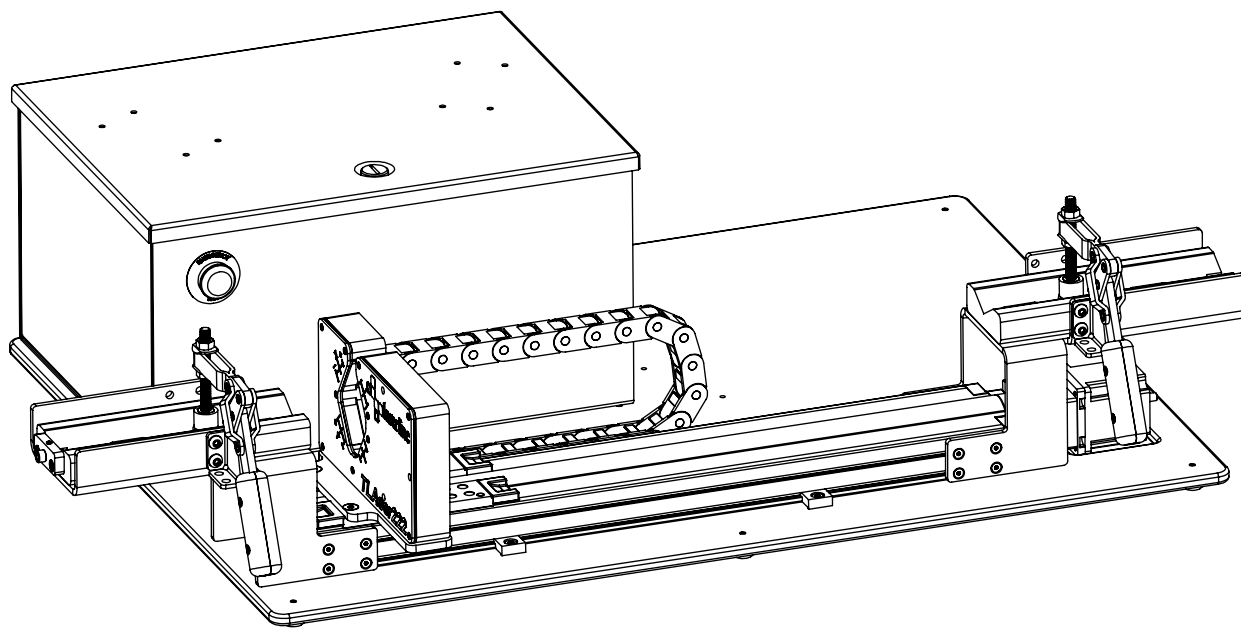

222 Linear Automation Overalls

INDEX

- (1) Cover Page
- (2) Dimensions

UNLESS OTHERWISE SPECIFIED:		NAME	DATE	 LaserLinc, Inc. Phone: 888-707-4892 Info@laserlinc.com www.laserlinc.com
DIMENSIONS ARE IN INCHES TOLERANCES: ANGULAR: MACH ± BEND ± TWO PLACE DECIMAL ±0.010 THREE PLACE DECIMAL ±0.005 FOUR PLACE DECIMAL ±0.0005 ANGLES ±2° UNMARKED FILLETS/ROUNDS R.0625 DE-BURR ALL PARTS		DRAWN BY:	DRP	
INTERPRET GEOMETRIC TOLERANCING PER:		TITLE: 6003-0000-00 222 Linear Automation Overalls		
MATERIAL FINISH DO NOT SCALE DRAWING		63 RA SURFACE FINISH ALL FEATURES MUST MEET SPECIFICATION AFTER PLATING BEFORE POWDER-COAT IF PLATED OR POWDER-COATED SEE FINISH MACHINE ALL SURFACES		
SIZE B DWG. NO. 6003-0000-00 SCALE: 1:6		REV A SHEET 1 OF 2		

PROPRIETARY AND CONFIDENTIAL

THE INFORMATION CONTAINED IN THIS DRAWING IS THE SOLE PROPERTY OF LASERLINC, INC. ANY REPRODUCTION IN PART OR AS A WHOLE WITHOUT THE WRITTEN PERMISSION OF LASERLINC, INC IS PROHIBITED.

D
C
B
A

D
C
B
A

8 7 6 5 4 3 2 1

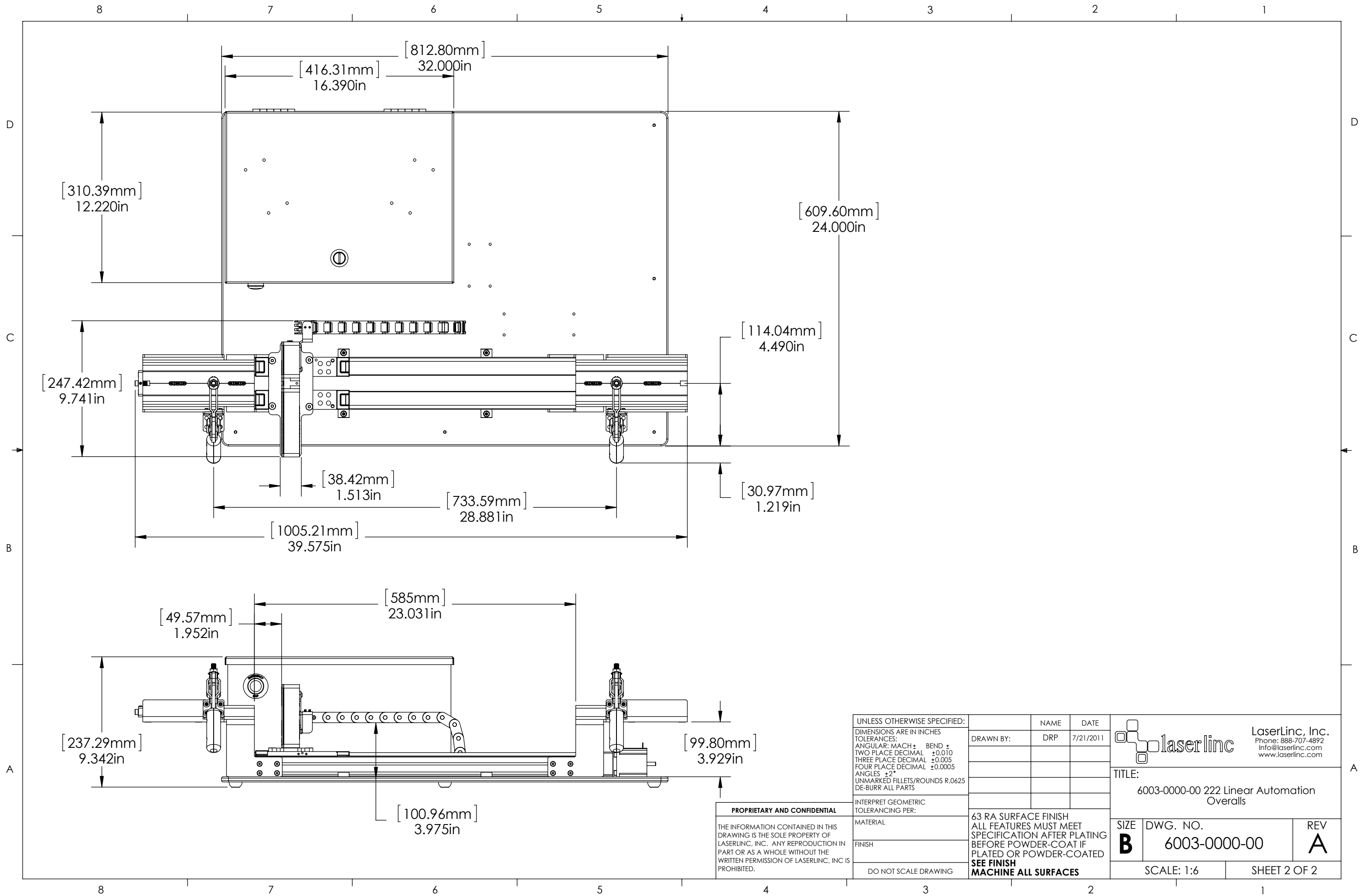

UNLESS OTHERWISE SPECIFIED:
 DIMENSIONS ARE IN INCHES
 TOLERANCES:
 ANGULAR: MACH ± BEND ±
 TWO PLACE DECIMAL ±0.010
 THREE PLACE DECIMAL ±0.005
 FOUR PLACE DECIMAL ±0.0005
 ANGLES ±2°
 UNMARKED FILLETS/ROUNDS R.0625
 DE-BURR ALL PARTS

INTERPRET GEOMETRIC
 TOLERANCING PER:
 MATERIAL
 FINISH
 DO NOT SCALE DRAWING

NAME	DATE
DRP	7/21/2011

63 RA SURFACE FINISH
 ALL FEATURES MUST MEET
 SPECIFICATION AFTER PLATING
 BEFORE POWDER-COAT IF
 PLATED OR POWDER-COATED
**SEE FINISH
 MACHINE ALL SURFACES**

PROPRIETARY AND CONFIDENTIAL
 THE INFORMATION CONTAINED IN THIS
 DRAWING IS THE SOLE PROPERTY OF
 LASERLINC, INC. ANY REPRODUCTION IN
 PART OR AS A WHOLE WITHOUT THE
 WRITTEN PERMISSION OF LASERLINC, INC IS
 PROHIBITED.

laserlinc LaserLinc, Inc.
 Phone: 888-707-4892
 Info@laserlinc.com
 www.laserlinc.com

TITLE:
 6003-0000-00 222 Linear Automation
 Overalls

SIZE	DWG. NO.	REV
B	6003-0000-00	A

SCALE: 1:6 SHEET 2 OF 2