

8 7 6 5 4 3 2 1

REVISIONS				
ZONE	REV.	DESCRIPTION	DATE	APPROVED
	A	Checked-in	10/19/2010	DRP

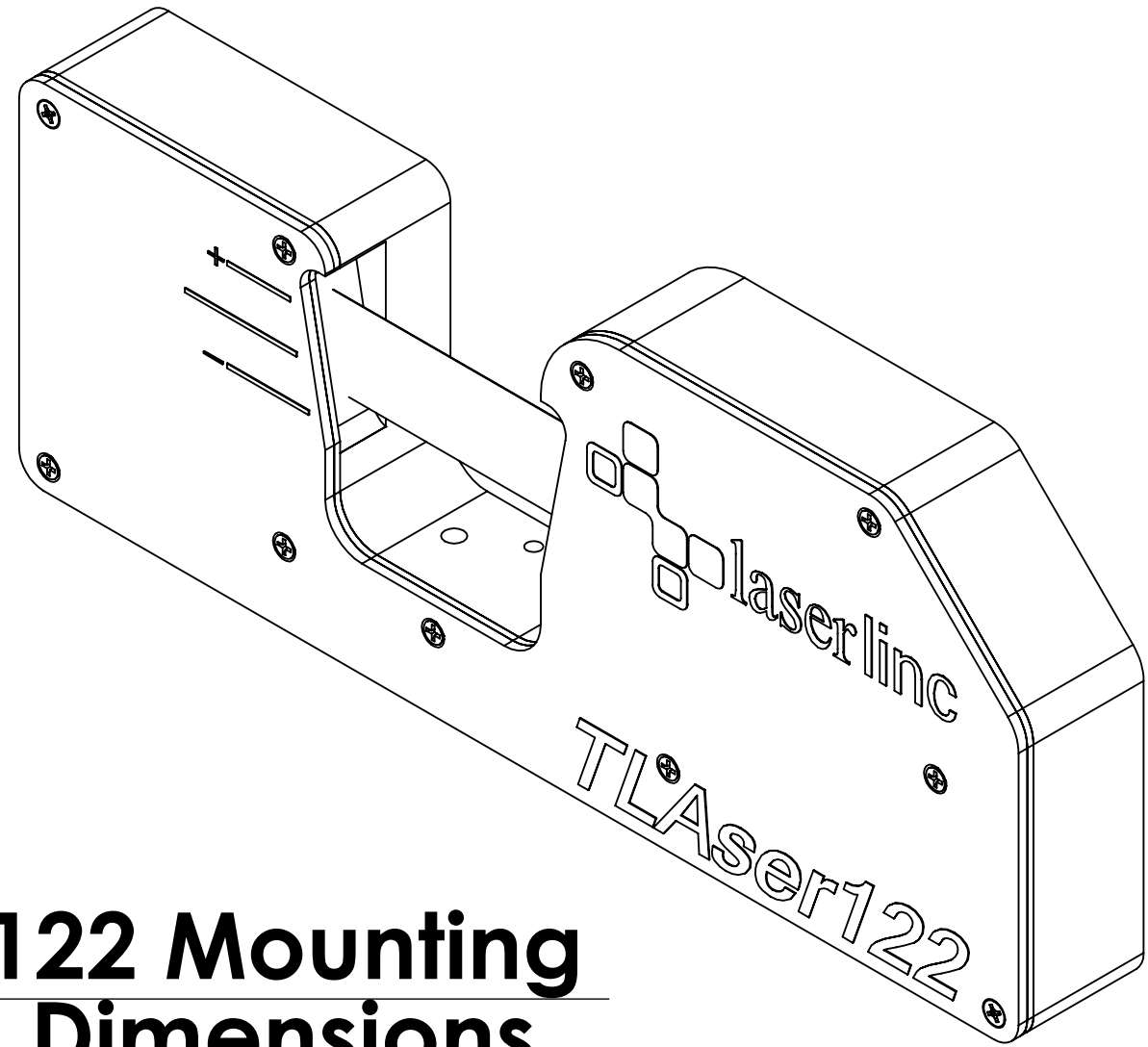

122 Mounting Dimensions

INDEX

- (1) Cover Page
- (2) Dimensions

UNLESS OTHERWISE SPECIFIED:		NAME	DATE	 LaserLinc, Inc. Phone: 888-707-4892 Info@laserlinc.com www.laserlinc.com
DIMENSIONS ARE IN INCHES TOLERANCES: ANGULAR: MACH ± BEND ± TWO PLACE DECIMAL ±0.010 THREE PLACE DECIMAL ±0.005 FOUR PLACE DECIMAL ±0.0005 ANGLES ±2° UNMARKED FILLETS/ROUNDS R.0625 DE-BURR ALL PARTS		DRAWN BY:	MAM	
INTERPRET GEOMETRIC TOLERANCING PER:				TITLE:
				0122-0000-00 122 Mounting Dimensions
PROPRIETARY AND CONFIDENTIAL THE INFORMATION CONTAINED IN THIS DRAWING IS THE SOLE PROPERTY OF LASERLINC, INC. ANY REPRODUCTION IN PART OR AS A WHOLE WITHOUT THE WRITTEN PERMISSION OF LASERLINC, INC IS PROHIBITED.		MATERIAL	63 RA SURFACE FINISH ALL FEATURES MUST MEET SPECIFICATION AFTER PLATING BEFORE POWDER-COAT IF PLATED OR POWDER-COATED SEE FINISH	
		FINISH		
		DO NOT SCALE DRAWING		SIZE B DWG. NO. 0122-0000-00 REV A SCALE: 3:4 SHEET 1 OF 3

8 7 6 5 4 3 2 1

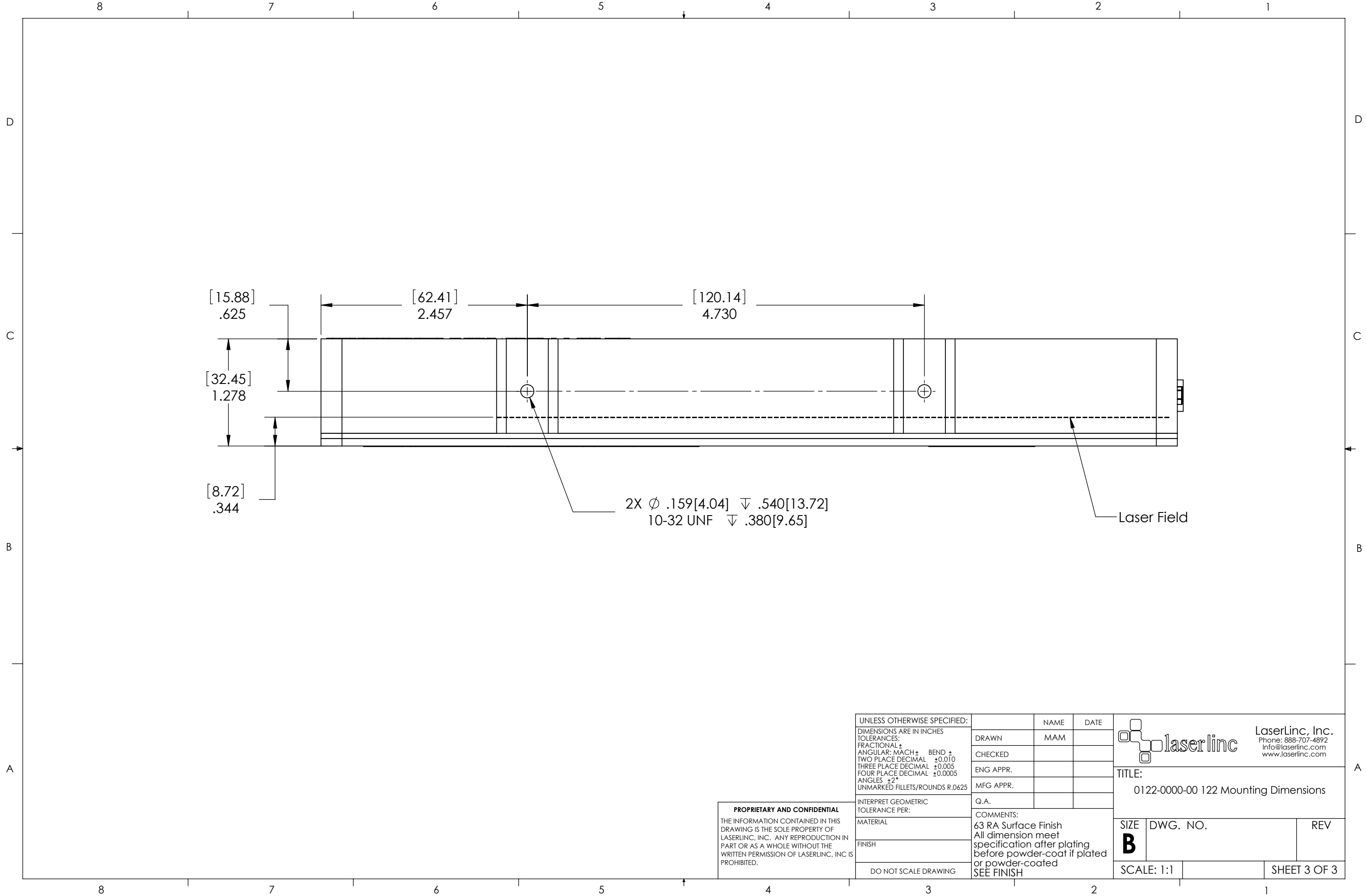

UNLESS OTHERWISE SPECIFIED: DIMENSIONS ARE IN INCHES TOLERANCES: FRACTIONAL ± ANGULAR: MACH ± BEND ± TWO PLACE DECIMAL ±0.010 THREE PLACE DECIMAL ±0.005 FOUR PLACE DECIMAL ±0.0005 ANGLES ±2° UNMARKED FILLETS/ROUNDS R.0625	DRAWN	NAME	DATE	 LaserLinc, Inc. Phone: 888-707-4892 Info@laserlinc.com www.laserlinc.com
	CHECKED	MAM		
	ENG APPR.			
	MFG APPR.			
	Q.A.			
INTERPRET GEOMETRIC TOLERANCE PER:	COMMENTS:			TITLE:
MATERIAL	63 RA Surface Finish All dimension meet specification after plating before powder-coat if plated or powder-coated SEE FINISH			0122-0000-00 122 Mounting Dimensions
FINISH	SIZE	DWG. NO.	REV	
DO NOT SCALE DRAWING	B			
	SCALE: 1:1			SHEET 3 OF 3

PROPRIETARY AND CONFIDENTIAL
 THE INFORMATION CONTAINED IN THIS DRAWING IS THE SOLE PROPERTY OF LASERLINC, INC. ANY REPRODUCTION IN PART OR AS A WHOLE WITHOUT THE WRITTEN PERMISSION OF LASERLINC, INC IS PROHIBITED.